

ROTATING ELECTRIC



Rotating Electric

Rotating Electric is a broad category that includes the following sub-categories:

- Starters
- Alternators
- Trim Motors
- Voltage Regulators
- Electrical Accessories



Starters - Applications

Starters cover the following applications:

- MerCruiser Gas and Diesel
- Johnson/Evinrude/BRP
- Suzuki
- Volvo Gas and Diesel
- Yamaha
- Sea-Doo
- Kawasaki PWC
- Honda PWC
- Arctic Cat PWC
- Yamaha PWC
- Yanmar Diesel
- Caterpillar

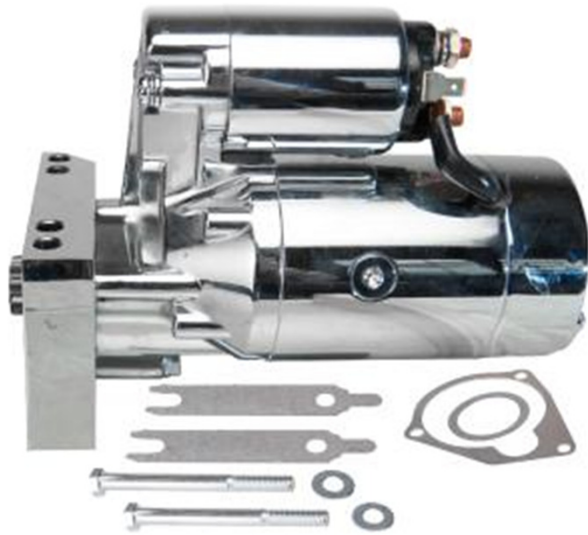

Alternators – Overview/Applications



Applications:

- Yanmar diesel
- Mercruiser
- OMC Sterndrive
- Crusader
- Yamaha Sterndrive
- Caterpillar
- Cummins
- Volvo (gas and diesel)



Trim Motors - Applications

Trim motors cover the following applications:

- Mercruiser
- Johnson/Evinrude/BRP
- OMC Cobra
- Volvo Penta
- Yamaha
- Honda
- Suzuki Sea-Doo
- Kawasaki PWC



Industry Leading Warranty

These and all Sierra products are backed by our industry leading warranty



The Best in the Business

- Limited lifetime
- We pay parts and labor
- We pay incidental charges
- We pay your posted shop rate

noweaklinks



Warranty Continued

- Due to the demanding environment that all rotating electric components are subject to, Sierra's limited lifetime warranty provides unparalleled peace of mind; protecting both you and your customer in the case of part failure. Paying all associated fees-including towing fees, parts replacement, incidental parts damage and posted shop labor rates no one protects you and your reputation like Sierra.



Features

- All **NEW** replacements
- Meet OEM specifications
- Meet or exceed OEM output for guaranteed performance
- High temperature epoxy armature provides strength to secure and insulate wires
- Permanent magnet units are designed for more torque and longer life
- 90/10 copper bushings or heavy duty needle bearings for longer service



Features

- All marine starters and alternators must be ignition-protected to reduce the possibility of explosion onboard.
- All Sierra starters and alternators meet UL standards for stern drive and inboard applications.
- They also comply with international CE standards required by the European Economic Community.
- Components plated and coated for maximum corrosion protection.



Marketing & Packaging Changes

In an effort to make the product more recognizable and endearing in the dealers eyes. You will notice the following changes with the fast moving items in 2015:

- Enhanced boxing-heavy duty boxes to protect the product during shipping.
- “Dealers Choice” stickers added to product for brand recognition.
- Full-colored graphic sleeve added to product for increased visibility.

